



 GOOD DESIGN AWARD® WINNER

EUROPEAN PRODUCT DESIGN AWARD

blinde™



TIMELESS, AUTHENTIC,  
ADAPTABLE, TRANSEASONAL  
- BLINDE IS A VERSATILE  
CONCRETE FURNITURE  
RANGE THAT COMBINES SLICK  
SILHOUETTES WITH LIGHTWEIGHT  
CUSTOM CONSTRUCTION. OUR  
COLLECTION OF FUNCTIONAL  
AND STATEMENT PIECES RANGE  
FROM TABLES TO PLANT POTS,  
AND ALSO COLLABORATES  
WITH ORIGINAL DESIGN AND  
EQUIPMENT MANUFACTURERS  
TO PRODUCE BESPOKE PIECES.

< Plant Pot  
Stitch 125



# LOW & MEDIUM TABLES

MODERN AND STYLISH, DURABLE AND LIGHTWEIGHT, BLINDE CONCRETE TABLES MAKE A STATEMENT IN ANY OUTDOOR OR INDOOR SPACE.

Choose from our range of low and medium, round, square and rectangular designs. Available in three neutral shades, we have a table for any space.

> Medium Table  
CIRC M2





< Low Table  
CIRC L2



< Low/Medium Tables  
CIRC M2 (left)  
CIRC L2 (right)



> Low Table  
CIRC L1



^ Low Table  
BLOC L4



^ Low Tables  
BLOC L1 (*left*)  
BLOC L3 (*middle*)  
BLOC L2 (*right*)



< Low Table  
BLOC L6



^ Medium Table  
CIRC M1



^ Low Table  
BLOC L6



^ Low Table  
BLOC L5



^ Low Table  
CIRC L1





^ Side Table  
SOLO R1



^ Low Table  
BLOC L6



< Low Table  
BLOC L5

# PLANT POTS

DECORATE YOUR INDOOR AND OUTDOOR AREAS WITH OUR DURABLE, LIGHTWEIGHT AND ON-TREND COLLECTION OF CONCRETE PLANT POTS.

Our 'Stitch' plant pots come in three natural concrete colours, with a selection of contemporary stitching colours. Their lightweight design makes them easy to move around. Choose from five different sizes to display potted plants for a fresh, natural look.

> Plant Pots  
Stitch Collection





^ Plant Pot  
Stitch 75



^ Plant Pot  
Stitch 75



^ Plant Pot  
Stitch 125



^ Plant Pots  
Stitch 125 (left)  
Stitch 50 (middle)  
Stitch 100 (right)



< Plant Pots  
Stitch Collection



## BLINDE MODEL SPECIFICATIONS

EVERYTHING YOU NEED TO KNOW  
ABOUT DIMENSIONS, COLOUR  
OPTIONS AND STYLES CAN BE FOUND  
ON THE FOLLOWING PAGES.

< Medium Table  
CIRC M1

# TABLES

## CIRC L1



Bone



Graphite



Natural

THIS ROUND SHAPED LOW CONCRETE TABLE SITS ON DISCRETE LEVELLING FEET. AT TWICE THE STRENGTH AND HALF THE WEIGHT OF TRADITIONAL CONCRETE, THEY ARE BUILT FOR HIGH PERFORMANCE IN ALL WEATHER CONDITIONS.

**CIRC L1**  
BLD.1.T.CIR.L1

**Dimensions**

L 1000mm [39.4"]  
W 1000mm [39.4"]  
H 339mm [13.3"]

**Weight**

Approx. 35.5kg / 78.1lbs

**Material**

Fluid™ Concrete Technology

**Colours**

Graphite, Natural and Bone

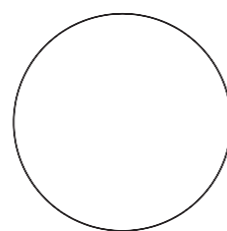

1000mm [39.4"]

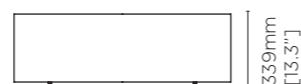

339mm [13.3"]

## CIRC M1



Natural



Bone



Graphite

AN ELEGANTLY ORGANIC ROUND CONCRETE TABLE WITH SOFT EDGES AND DISCRETE LEVELLING FEET. AT TWICE THE STRENGTH AND HALF THE WEIGHT OF TRADITIONAL CONCRETE, THEY ARE BUILT FOR HIGH PERFORMANCE IN ALL WEATHER CONDITIONS.

**CIRC M1**  
BLD.1.T.CIR.M1

**Dimensions**

L 772mm [30.4"]  
W 772mm [30.4"]  
H 401mm [15.8"]

**Weight**

Approx. 19kg / 41.8lbs

**Material**

Fluid™ Concrete Technology

**Colours**

Graphite, Natural and Bone

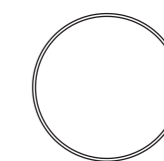

772mm [30.4"]



401mm [15.8"]



# TABLES

## CIRC L2



Natural



Bone



Graphite

## CIRC M2



Graphite



Bone



Natural

AVAILABLE IN TWO DIFFERENT SIZES - LOW AND MEDIUM, THESE ROUND SHAPED CONCRETE TABLES SIT ON DISCRETE LEVELLING FEET. AT TWICE THE STRENGTH AND HALF THE WEIGHT OF TRADITIONAL CONCRETE, THEY ARE BUILT FOR HIGH PERFORMANCE IN ALL WEATHER CONDITIONS.

### CIRC L2 BLD.1.T.CIR.L2

#### Dimensions

L 762mm [30"]  
W 762mm [30"]  
H 351mm [13.8"]

#### Weight

Approx. 23.5kg / 51.7lbs

#### Material

Fluid™ Concrete Technology

#### Colours

Graphite, Natural and Bone

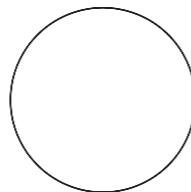

762mm [30"]

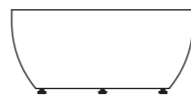

351mm  
[13.8"]

### CIRC M2 BLD.1.T.CIR.M2

#### Dimensions

L 1000mm [39.4"]  
W 1000mm [39.4"]  
H 504mm [19.8"]

#### Weight

Approx. 44.5kg / 97.9lbs

#### Material

Fluid™ Concrete Technology

#### Colours

Graphite, Natural and Bone

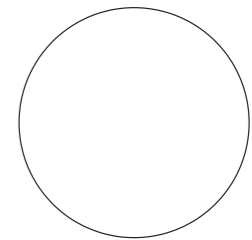
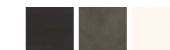

1000mm [39.4"]

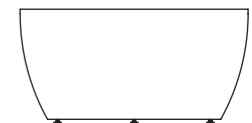

504mm  
[19.8"]

# BLOC L3

# BLOC L2

# BLOC L1



Natural



Graphite



Bone

AVAILABLE IN THREE DIFFERENT SIZES, THESE RECTANGULAR SHAPED CONCRETE TABLES SIT ON DISCRETE LEVELLING FEET. AT TWICE THE STRENGTH AND HALF THE WEIGHT OF TRADITIONAL CONCRETE, THEY ARE BUILT FOR HIGH PERFORMANCE IN ALL WEATHER CONDITIONS.

**BLOC L3**  
BLD.1.T.BLC.L3

**Dimensions**  
L 1700mm [67"]  
W 500mm [19.7"]  
H 370mm [14.5"]

**Weight**  
Approx. 66kg / 145.2lbs

**Material**  
Fluid™ Concrete Technology

**Colours**  
Graphite, Natural and Bone



1700mm [67"]



500mm [19.7"]

370mm [14.5"]



**BLOC L2**  
BLD.1.T.BLC.L2

**Dimensions**  
L 1200mm [47"]  
W 400mm [15.7"]  
H 320mm [12.6"]

**Weight**  
Approx. 33kg / 72.6lbs

**Material**  
Fluid™ Concrete Technology

**Colours**  
Graphite, Natural, Bone



1200mm [47"]



400mm [15.7"]

320mm [12.6"]



**BLOC L1**  
BLD.1.T.BLC.L1

**Dimensions**  
L 1000mm [39.4"]  
W 400mm [15.7"]  
H 270mm [10.7"]

**Weight**  
Approx. 25.5kg / 56.1lbs

**Material**  
Fluid™ Concrete Technology

**Colours**  
Graphite, Natural and Bone



1000mm [39.4"]



400mm [15.7"]

270mm [10.7"]



**BLOC  
L4**

**BLOC  
L5**



Natural



Bone



Graphite



Graphite

**SQUARE AND RECTANGULAR SHAPED CONCRETE TABLES THAT SIT ON DISCRETE LEVELLING FEET. AT TWICE THE STRENGTH AND HALF THE WEIGHT OF TRADITIONAL CONCRETE, THEY ARE BUILT FOR HIGH PERFORMANCE IN ALL WEATHER CONDITIONS.**

**BLOC L4**  
BLD.1.T.BLC.L4

**Dimensions**

L 1000mm [39.4"]  
W 1000mm [39.4"]  
H 339mm [13.3"]

**Weight**

Approx. 36.9kg / 81.2lbs

**Material**

Fluid™ Concrete Technology

**Colours**

Graphite, Natural and Bone



1000mm [39.4"]



1000mm [39.4"]



339mm [13.3"]

**BLOC L5**  
BLD.1.T.BLC.L5

**Dimensions**

L 1650mm [65"]  
W 1000mm [39.4"]  
H 339mm [13.3"]

**Weight**

Approx. 83kg / 182.6lbs

**Material**

Fluid™ Concrete Technology

**Colours**

Graphite, Natural and Bone

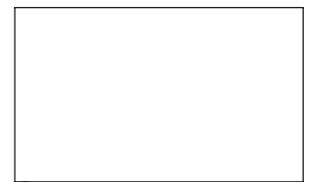

1650mm [65"]



1000mm [39.4"]



339mm [13.3"]

# TABLES

## BLOC L6



## SOLO R1



RECTANGULAR SHAPED CONCRETE TABLE FEATURING SIMPLE SHADOWLINE KICK. AT TWICE THE STRENGTH AND HALF THE WEIGHT OF TRADITIONAL CONCRETE, THEY ARE BUILT FOR HIGH PERFORMANCE IN ALL WEATHER CONDITIONS.

**BLOC L6**  
BLD.1.T.BLC.L6

**Dimensions**  
L 1270mm [50"]  
W 762mm [30"]  
H 296mm [11.7"]

**Weight**  
Approx. 42kg / 92.4bs

**Material**  
Fluid™ Concrete Technology

**Colours**  
Graphite, Natural and Bone

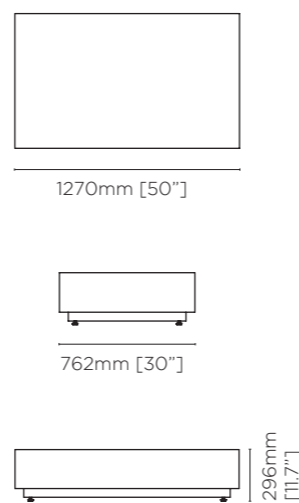

SOLO R1 IS A VERSATILE PIECE OF FURNITURE, DOUBLING AS EITHER A STAND-ALONE SIDE TABLE OR TRENDY STOOL. MANUFACTURED FROM FLUID CONCRETE TECHNOLOGY, SOLO R1 IS LIGHT FOR EASY MOBILITY, BUT HEAVY ENOUGH FOR COMMERCIAL USE. SOLO R1 FEATURES HEIGHT ADJUSTABLE ARTICULATING FEET FOR STABILITY ON NEARLY ANY SURFACE.

**SOLO R1**  
BLD.1.T.SOL.R1

**Dimensions**  
L 304mm [12"]  
W 304mm [12"]  
H 468mm [18.4"]

**Weight**  
Approx. 15kg / 33lbs

**Material**  
Fluid™ Concrete Technology

**Colours**  
Graphite, Natural and Bone

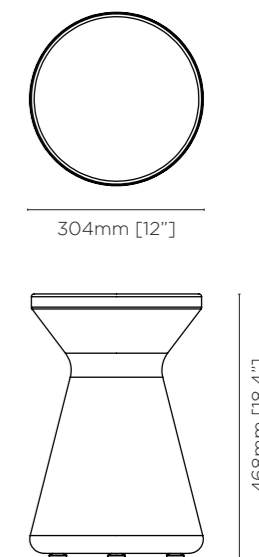

# STITCH 25



Bone with Yellow Stitch



Natural with Black Stitch



Graphite with Orange Stitch



Bone with White Stitch



Graphite with Red Stitch



Bone with White Stitch



Natural with Grey Stitch



Graphite with Yellow Stitch

DISPLAY FRESH OR FAUX POTTED PLANTS IN THESE STYLISH PLANT POTS AVAILABLE IN A RANGE OF SIZES AND COLOURS. THE POTS FEATURE A STITCHED EMBELLISHMENT ON THE SEAM IN YOUR CHOSEN COLOUR. SINGULARLY THEY LOOK STUNNING, AS A SET, THEY LOOK SENSATIONAL.

**STITCH 25**  
BLD.I.P.STI.25

**Dimensions**

L 677mm [26.7"]  
W 583mm [23"]  
H 417mm [16.4"]

**Pot Opening Dimensions**

L 617mm [24.3"]  
W 410mm [16.1"]

**Maximum Internal Pot Size**

Ø 355mm [14"]  
H 280mm [11"]

**Weight**

Approx. 16kg / 35.2lbs

**Material**

Fluid™ Concrete Technology  
Decorative Rope

**Colours**

**Concrete Pot**  
Graphite, Natural and Bone



**Stitch Rope**

Yellow, Grey, Black, White, Orange and Red



617mm [24.3"]

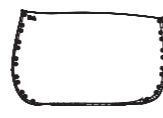

677mm [26.7"]

410mm [16.1"]



417mm [16.4"]

583mm [23"]

355mm [14"]

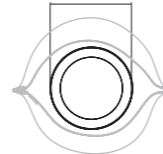

**STITCH 50**  
BLD.I.P.STI.50

**Dimensions**

L 914mm [36"]  
W 788mm [31"]  
H 563mm [22.2"]

**Pot Opening Dimensions**

L 836mm [32.9"]  
W 555mm [21.8"]

**Maximum Internal Pot Size**

Ø 500mm [16.6"]  
H 380mm [15"]

**Weight**

Approx. 31.3kg / 68.9lbs

**Material**

Fluid™ Concrete Technology  
Decorative Rope

**Colours**

**Concrete Pot**  
Graphite, Natural and Bone

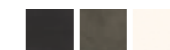

**Stitch Rope**

Yellow, Grey, Black, White, Orange and Red

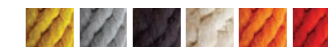

836mm [32.9"]



914mm [36"]

555mm [21.8"]



563mm [22.2"]

788mm [31"]

500mm [16.6"]

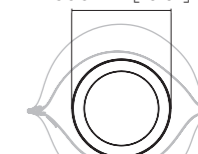

# STITCH 75



Natural with  
Black Stitch



Graphite with  
Grey Stitch



Bone with  
Orange Stitch



Natural with  
Yellow Stitch



Bone with  
White Stitch



Natural with  
Orange Stitch



Graphite with  
Black Stitch



Bone with  
Yellow Stitch

# STITCH 100

## STITCH 75 BLD.I.P.STI.75

### Dimensions

L 970mm [38.2"]  
W 838mm [33"]  
H 598mm [23.5"]

### Pot Opening Dimensions

L 887mm [34.9"]  
W 588mm [23.1"]

### Maximum Internal Pot Size

Ø 555mm [21.8"]  
H 400mm [15.7"]

### Weight

Approx. 33.9kg / 74.6lbs

### Material

Fluid™ Concrete Technology  
Decorative Rope

### Colours

Concrete Pot  
Graphite, Natural and Bone



### Stitch Rope

Yellow, Grey, Black, White, Orange  
and Red

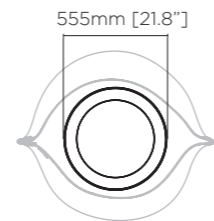
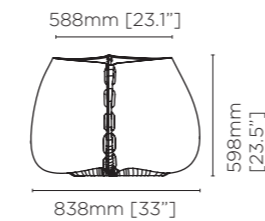
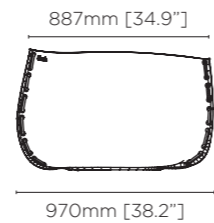

## STITCH 100 BLD.I.P.STI.100

### Dimensions

L 1115mm [43.9"]  
W 962mm [37.9"]  
H 687mm [27"]

### Pot Opening Dimensions

L 1019mm [40.1"]  
W 677mm [26.6"]

### Maximum Internal Pot Size

Ø 605mm [23.8"]  
H 460mm [18"]

### Weight

Approx. 37.7kg / 82.9lbs

### Material

Fluid™ Concrete Technology  
Decorative Rope

### Colours

Concrete Pot  
Graphite, Natural and Bone



### Stitch Rope

Yellow, Grey, Black, White, Orange  
and Red

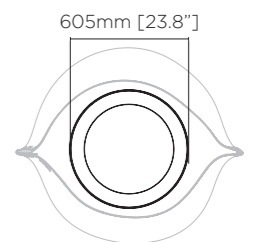
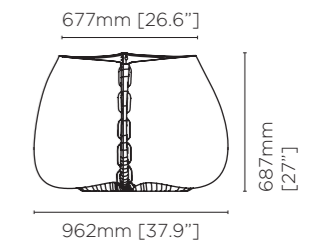
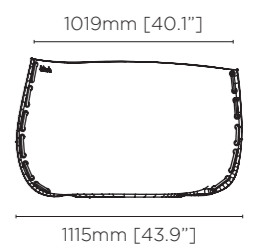
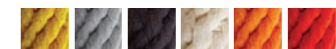

# STITCH 125

# STITCH COLOUR COMBINATIONS



Graphite with Yellow Stitch



Bone with Red Stitch

Natural with Orange Stitch

Graphite with Grey Stitch

**STITCH 125**  
BLD.1.P.STI.125

**Dimensions**

L 1219mm [48"]  
W 1048mm [41.3"]  
H 750mm [29.5"]

**Pot Opening Dimensions**

L 1113mm [43.8"]  
W 740mm [29.1"]

**Maximum Internal Pot Size**

Ø 640mm [25.2"]  
H 550mm [21.7"]

**Weight**

Approx. 50.7kg / 111.5lbs

**Material**

Fluid™ Concrete Technology  
Decorative Rope

**Colours**

**Concrete Pot**  
Graphite, Natural and Bone



**Stitch Rope**

Yellow, Grey, Black, White, Orange and Red

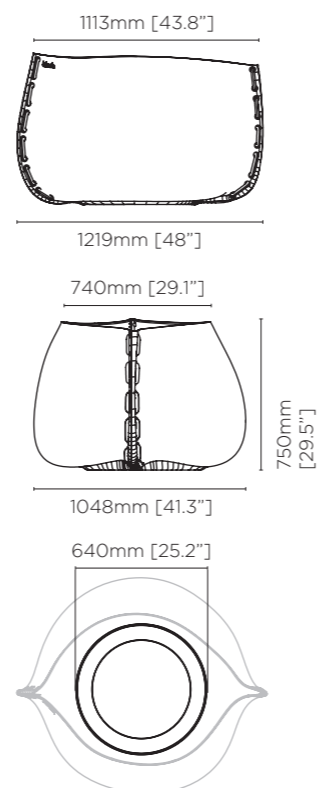

Graphite



Yellow Stitch



Grey Stitch



Black Stitch



White Stitch



Orange Stitch

Natural



Yellow Stitch



Grey Stitch



Black Stitch



White Stitch



Orange Stitch

Bone



Yellow Stitch



Grey Stitch



Black Stitch



White Stitch



Orange Stitch

# FLUID™ CONCRETE TECHNOLOGY

CONCRETE IS A COVETED MATERIAL IN THE BUILDING AND DESIGN INDUSTRIES DUE TO ITS DURABLE COMPOSITION, NATURAL APPEARANCE AND SIMPLE CONSTRUCTION. HOWEVER, WHEN IT COMES TO CREATING BEAUTIFUL, LONG-LASTING FINISHES FOR FUNCTIONAL CONCRETE SURFACES, THERE'S MORE THAN MEETS THE EYE.

From sourcing quality ingredients and mixing raw materials through to polishing and packaging, our Fluid™ Concrete Technology delivers a streamlined yet sophisticated system that produces exceptionally robust, handcrafted products.

Our manufacturing facility prides itself on delivering a professional service that is focused on best practice procedures, incorporates multiple quality control touch points, and is executed with an environmentally friendly mindset.

## Colours



### Natural

Our most versatile shade, Natural is an organic concrete finish that seamlessly integrates into contemporary or traditional spaces.

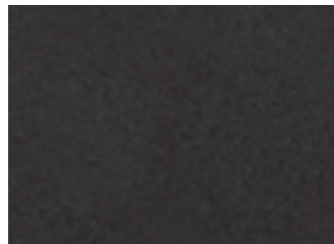

### Graphite

Sleek and modern, Graphite demands attention. Familiar yet fresh, Graphite complements a range of alfresco spaces.

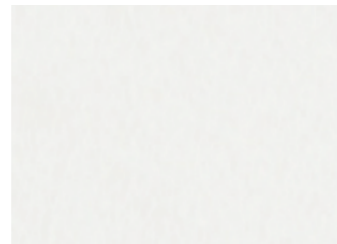

### Bone

A trendsetting finish with a clean and crisp texture. Bone is inspired by coastal tones and peaceful spaces.

Reproduction of this catalogue in any manner, in any language, in whole or in part without prior written permission is prohibited. MAD Design Group reserves the right to correct any errors or misprints. We also reserve the right to alter information without notification. The information provided herein is believed to be correct but is not guaranteed. V0319

## The Concrete

Fluid™ Concrete Technology uses a custom composition of green cement combined with 95% recycled natural materials.

Our special moulding process incorporates multiple layers of structural meshing combined with a carefully mixed slurry to produce a high-quality and dimensionally stable concrete that is relatively lightweight and incredibly strong.

With a curing process that allows each piece to rest and set in controlled conditions, we are able to produce consistently beautiful products that are built to last.

## The Coating

Developed in-house by our research and development team and a highly experienced German coating supplier, Fluid™ products are coated with a water-resistant barrier to ensure the green concrete composite shell becomes totally inert and isn't subject to temperature fluctuations or moisture saturation.

Each product is fully enveloped in a specially formulated solvent-based solution that protects the raw materials from environmental weathering. This enables us to deliver perfection from the base raw materials right through to the finished product - working from the inside out, to achieve an exceptionally robust product that is purpose built.



### Eco-friendly

Made from a combination of green cement and 95% recycled natural materials that absorb CO2 during the curing process, our composites are 100% recyclable and release minimal greenhouse gas emissions.



### Quality Control

Every piece is marked with a unique serial number for quality control and traceability purposes. They're also dimensionally stable with low expansion and contraction rates.

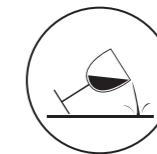

### Stain Resistant

Rigorous testing confirms the surface is impervious to ethanol, wine, vinegar, oil, mustard, tomato ketchup, salt, soy, bleach, espresso coffee, window cleaner, and more. (Turmeric should be avoided.)



### Environment Resistant

Fluid™ concrete is resistant to water, fire, insects, termites, mold and mildew. Fully cured, non-hydraulic concrete does not retain water, meaning it is resistant to freezing and thawing.

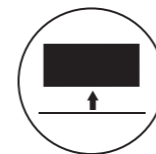

### Lightweight

Sturdy yet lightweight composition creates easily relocated furniture solutions.

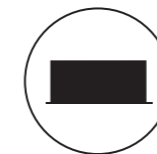

### Seamless Construction

We generate and work with moulds capable of producing unibody products which are seamless and free from join lines.

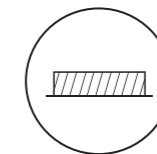

### Durable Surface

An exceptionally strong adhesion creates a coating that does not flake, peel or crack, and can withstand extreme weather variations and long UV exposure.



### UV Resistant

Even when our products were exposed for 144 hours in 12-hour cycles to water spray, UV rays, and water condensation, colours retained their depth and luster.



blinde  
design  
.com

blinde.